



**Mechanimix**

# SIDE ENTRY AGITATOR | VMG Series

Professional Mixing Technologies

## VMG Series Overview

**VMG Series Side Entry Agitators** are optimized for processes requiring low to medium viscosity and homogeneous mixing, featuring a vertical motor configuration, a custom-cast housing, and a gear-driven system. Its compact design, easy installation, and low maintenance requirements make it stand out. The **VMG Series** enhances process stability while maintaining energy efficiency. The gear drive system eliminates the need for an external reducer, simplifying the system and making maintenance easier. It also allows for mechanical seal replacement while the tank remains full.

With various shaft lengths, impeller types, and sealing options available, the **VMG Series** can be adapted to a wide range of industries and applications. It is a reliable and cost-effective solution used confidently in sectors such as petroleum, water treatment, chemical processing, food, cosmetics, and cleaning products



**VMG**

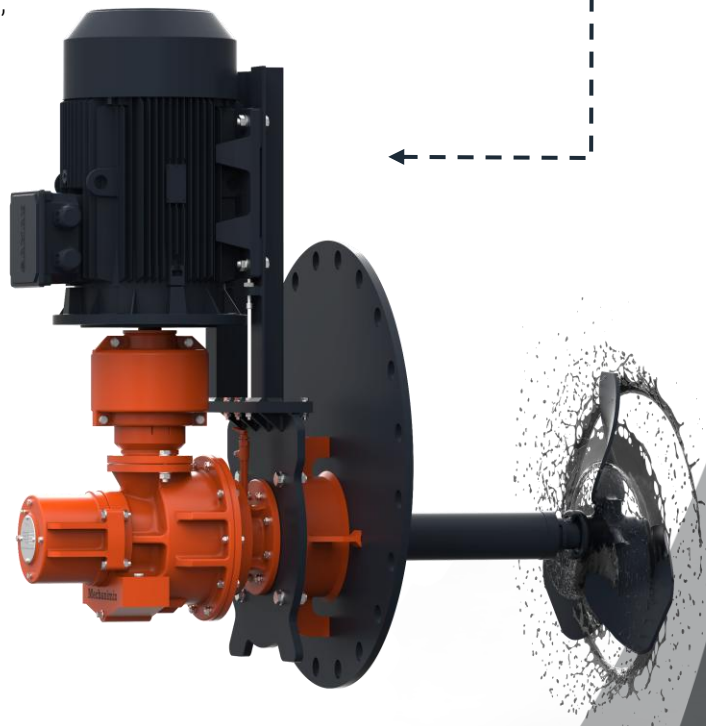

Propeller Type	GM, GDM, GDS, HWM, HWM-B
Propeller Diameter	300-1200 [mm]
Shaft Diameter	20-120 [mm]
Shaft Length	Up to 2 meters
Motor Power	1.1 – 37 [kW] (low speed, high torque)
Materials	Stainless Steel, Carbon Steel, Cast Iron, Super Duplex
Sealing System	Mechanical Seal
Models	AGI-10535 Models
Industries	Petroleum, Wastewater, Chemical, Mining, Paint, Food and Beverage

# VMG Series – Application Areas and Technical Advantages

## Professional Mixing Technologies

### Proven Success in Real-World Applications

Thanks to its customizable structure tailored to actual process needs, the VMG Series is widely and reliably used across many industries. Below are some common application areas:

#### Typical Application Areas

##### Petroleum, Fuel & Energy Derivatives

Ideal for the distribution of fuel additives, maintaining homogeneity in solvent tanks, and preventing sedimentation of low-viscosity hydrocarbons. Fixed-speed systems reduce foaming risk and ensure safe mixing.

##### Chemicals & Auxiliary Chemicals

Ensures homogeneous mixing of low-viscosity chemicals such as coagulants and flocculants. Ideal for substances that tend to settle when static.

##### Water & Wastewater Treatment

Provides continuous mixing in biological and chemical treatment basins. Ensures effective dissolution in pH adjustment tanks prior to sedimentation.

##### Cosmetics & Cleaning Products

Used during the dissolution and stabilization phases of products such as shampoo, surface cleaners, and liquid soap. Compatible with impeller designs that minimize foam formation.

##### Food & Beverage

Fixed-speed mixing in pre-dissolution tanks for sugary solutions, flavor-water blends, and liquid additives.

##### Storage & Tank Homogenization

Prevents sedimentation and preserves content uniformity in large-volume liquid storage tanks.

##### Emulsion & Additive Mixing

Enables stable emulsion formation and ensures even distribution of additives.

##### Energy Efficiency in Large-Volume Tanks

Side-entry agitators with vertically mounted gear motors provide high efficiency with low energy consumption in large storage tanks. They prevent stratification, reduce sludge buildup, and maintain consistent product quality. The side-entry design also ensures easy maintenance and operational flexibility.

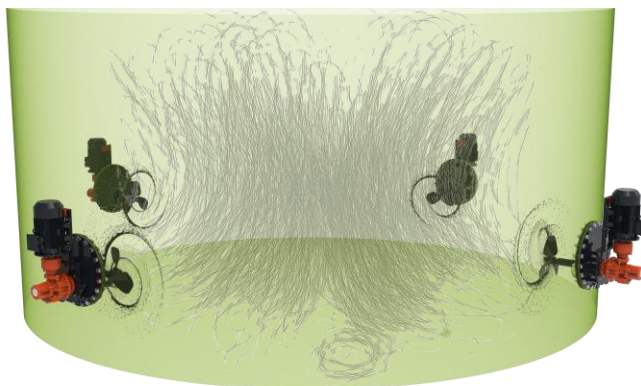

VMG Series Side-Entry Agitator Tank Simulation



Storage Tank Farm



Food Industry Product Preparation Tanks

# VMG Series Application Areas and Technical Advantages

## Professional Mixing Technologies

### Numerical Validation of Mixing Performance with CFD Analysis

#### CFD Post A – Velocity Distribution (Velocity Gradient Map)

In this analysis, the velocity distribution within different regions of the tank during mixer operation is visualized using a color scale.

Blue areas represent low-velocity zones, while red areas indicate high-velocity regions.

The observed symmetrical velocity pattern demonstrates uniform fluid distribution throughout the tank with minimal dead zones.

This indicates an ideal mixing scenario for maintaining product integrity.

#### CFD Post B – Streamlines & Flow Structure (Streamlines & Vector Fields)

This visualization illustrates the streamlines and flow directions within the tank.

The three-dimensional circulation generated by the impeller causes the fluid to move both horizontally and vertically.

Such a circulatory flow prevents sedimentation and enhances dissolution.

The combined downward and cross-directional flow confirms that the entire tank volume is being utilized effectively.

#### CFD Post C – Particle Tracking Visualization

In this simulation, the trajectories of freely moving particles within the fluid are visualized.

The turbulence and rotational motion induced by the agitator ensure that particles are dispersed throughout the entire tank volume and remain in constant motion.

This is particularly beneficial for achieving complete mixing of additives, pigments, flocculants, or dissolvable chemicals.

The visualization confirms not only the volumetric but also the dynamic continuity of the mixing process.

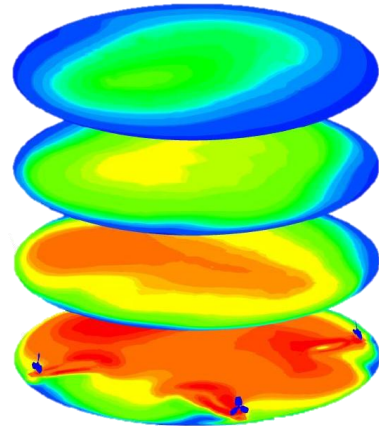

CFD Post A

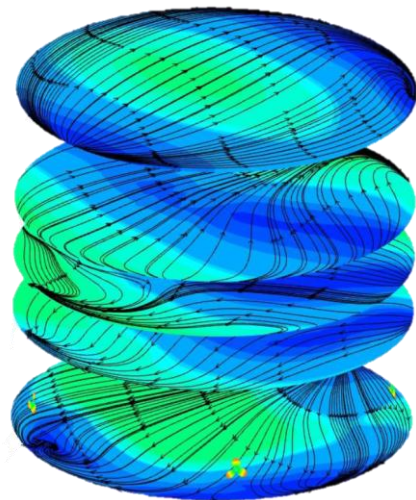

CFD Post B



# VMG Series – Mixing Technology and System Architecture

## Professional Mixing Technologies

### Optimization of Mixing Efficiency

Mechanimix utilizes advanced CFD (Computational Fluid Dynamics) analysis and a highly sophisticated laboratory to optimize mixer designs.

These analyses and experiments provide in-depth insights into velocity distribution, flow patterns, dead zones, and shear forces.

The resulting data enables the optimization of impeller geometry and helps balance energy consumption with pumping capacity.



Efficiency Optimization of HWM Impeller Using CFD

### Mechanical Structure and System Components

The VMG Series Side Entry Agitators are equipped with the following key components. This configuration provides high efficiency and ease of maintenance, adaptable to various process conditions. Units are available in materials such as stainless steel, cast iron, or duplex steel.

- Vertically mounted motor (medium to high speed, optimized torque)
- Mechanical seal (available in single, double, or cartridge configurations for reliable sealing)
- Welded or modular shaft (customizable to process requirements and tank design)
- MMX-Lock, Locking Mechanism (allows flow isolation during maintenance)
- Flange connection (enables fast and secure installation)

### Impeller Design and Performance

The impeller is a key component in achieving optimal mixing efficiency. Poorly designed impellers can lead to uneven flow, dead zones, and increased energy consumption.

The VMG Series is optimized with application-specific impeller geometry, blade angle, and rotational speed to deliver stable mixing, reduce energy losses, and extend equipment lifespan.

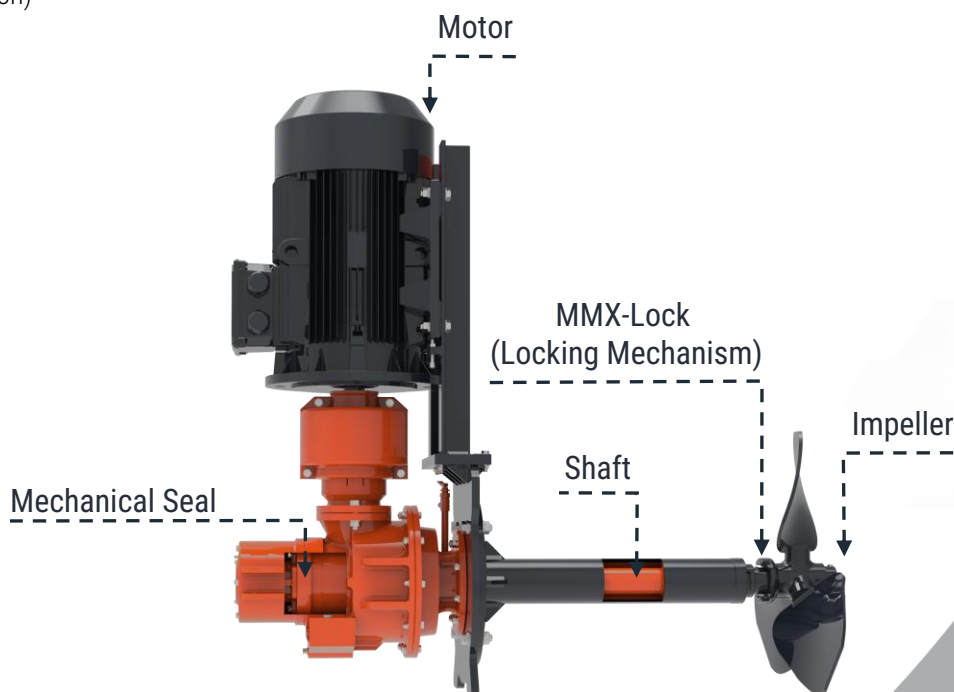

# VMG SERIES – MECHANICAL SEAL ACCESS AND MAINTENANCE EASE

## Professional Mixing Technologies

### Process-Friendly Design

The mechanical seals used in VMG Series Side Entry Agitators provide both high-integrity sealing and easy, user-friendly maintenance.

The seal unit is designed to be easily replaced without stopping production or fully emptying the tank.

This feature offers a significant advantage for industries that require high process continuity.

### Ease of Maintenance and Replacement

- The mechanical seal can be easily removed and replaced from the rear side (motor side) of the unit.
- There is no need to disassemble the motor or gear unit for this operation.
- The seal can be serviced without fully draining the tank.
- The MMX-Lock Locking Mechanism safely isolates product flow during maintenance, preventing any leakage to the environment.
- The seal unit features a cartridge-type and compact design, ensuring minimum service time.
- No alignment is required during installation, reducing the risk of operator error.
- Compatible with double-acting and pressurized seal systems (optional).
- Special options are available for use in high temperature, corrosive environments, or ATEX-classified zones..

### Advantages

- Minimal downtime and cost on the production line
- Fast, safe, and ergonomic access for service personnel
- No need to disassemble the tank or equipment
- Environmental safety during operation ensured by the MMX-Lock, Locking Mechanism
- User-friendly maintenance process and modular system integration

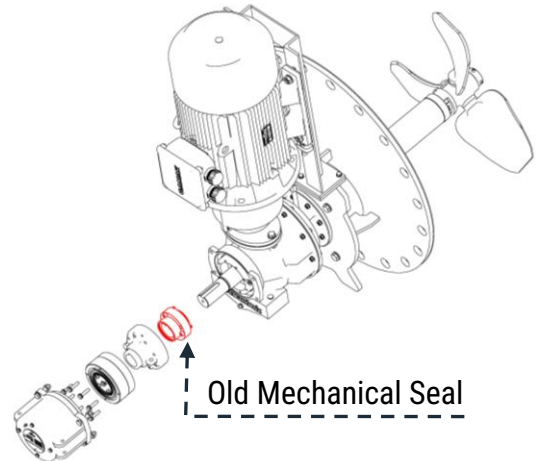

Mechanical Seal Replacement – Step 1

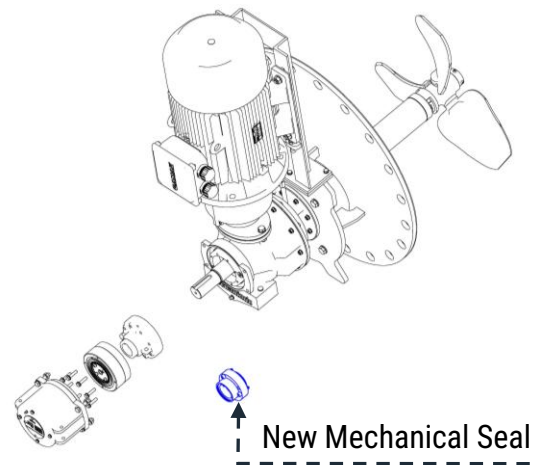

Mechanical Seal Replacement – Step 2

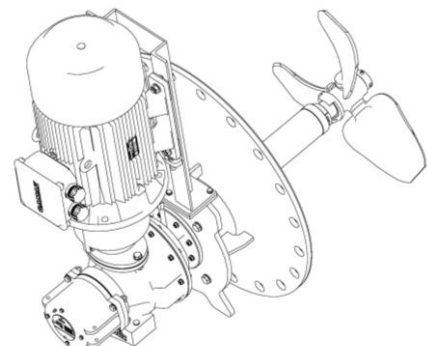

Mechanical Seal Replacement – Step 3

# VMG Series Agitator Dimensions and Application Areas

Professional Mixing Technologies

## Side-Entry VMG Agitator Dimensions



VMG series agitators are suitable for use in storage and process tanks ranging from 1 m<sup>3</sup> to 100,000 m<sup>3</sup>. They are optimized for varying viscosities, densities, and liquid properties.

Thanks to their modular design, they offer the ideal solution for every process.

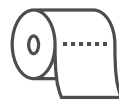
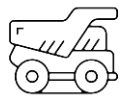
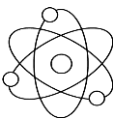

Mechanimix designs the VMG Series side-entry agitators for medium and low-viscosity liquids, slurry environments, chemical processes, and applications requiring thermal stability.

This series delivers optimum performance under demanding process conditions, including petroleum and fuel storage, wastewater treatment, chemical solution preparation, and paint and asphalt tanks.

By tailoring the solution to the tank geometry and mixing requirements, the VMG Series enhances overall process efficiency.

