

# Impellers | TVM Series

Professional Mixing Technologies

## Next Generation Efficiency in Mechanical Mixing Technologies

The TVM impeller is engineered for high-performance suspension and efficient axial flow, making it an ideal solution for long and deep tank applications. Its unique blade geometry delivers excellent solid lifting capability, fast mixing times, and superior heat-transfer performance while maintaining low energy consumption. Designed to handle low-viscosity fluids and systems requiring continuous particle suspension, the TVM provides reliable and uniform mixing across a wide range of industrial processes. This makes it a preferred choice in crystallization, polymerization, and hydrometallurgical operations where stable, high-efficiency suspension is critical.

### INDUSTRIES

- Chemical processing
- Polymer manufacturing
- Active Pharmaceutical Ingredient (API) production
- Specialty consumables
- Hydrometallurgical operations

### APPLICATIONS

- Crystallization processes
- Precipitation and solids formation
- Suspension and emulsion polymerization

### ADVANTAGES

- Low power consumption with efficient mixing
- Superior heat-transfer characteristics
- Reduced mixing time with stable axial flow
- Excellent solid suspension in deep tanks

### FEATURES

- High-suspension axial-flow impeller
- Suitable for low-viscosity and dilute systems
- Uniform energy distribution ensuring consistent process quality
- High particle velocity enhances solid dispersion

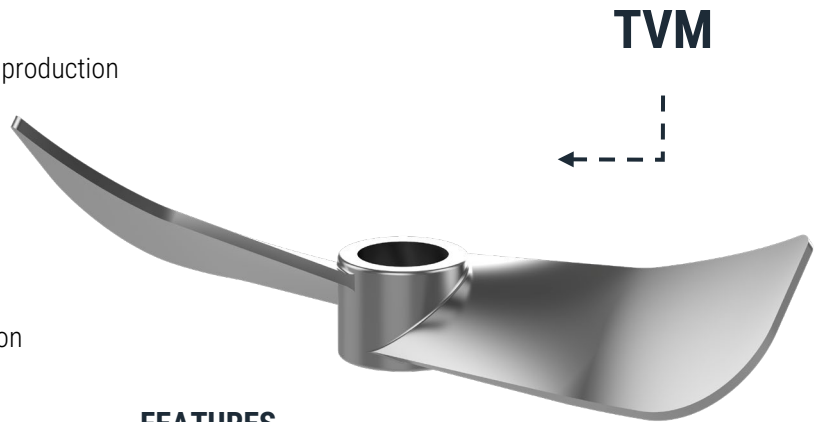

# Material Variants and Application Range

## Professional Mixing Technologies



**TVM**  
(Stainless Steel)

### Material

- High-grade stainless steel

### Features

- Wide-blade, low-shear axial-flow design
- Polished, hygienic surface suitable for clean operations
- Excellent solid-lifting capability for deep tanks
- Efficient axial pumping with minimal turbulence

### Typical Applications

- Crystallization and precipitation
- Suspension & emulsion polymerization
- API and fine-chemical production
- Long-tank solid suspension
- High-efficiency mixing for low-viscosity fluids

### Advantages

- High suspension capability
- Fast mixing with optimized axial flow
- Excellent heat-transfer performance



**TVM**  
(Rubber Lining)

### Material

- Carbon-steel impeller body with rubber lining

### Features

- Enhanced abrasion resistance for particle-rich systems
- Rubber layer absorbs impact and reduces mechanical wear
- Suitable for slurry-based or mineral-rich suspensions
- Stable axial pumping flow with low turbulence

### Typical Applications

- Slurry precipitation and crystallization
- Hydrometallurgical leaching processes
- Particle-rich suspension mixing
- Phosphate and mineral-processing plants

### Advantages

- Extended lifespan in abrasive environments
- Lower wear on blades due to rubber damping
- Reduced maintenance requirements

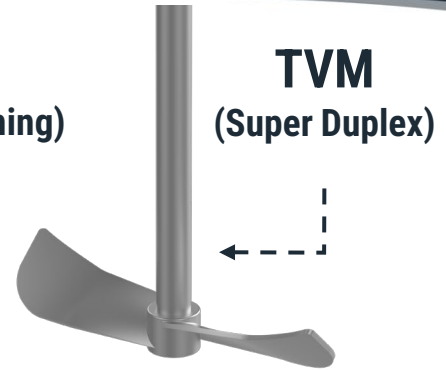

**TVM**  
(Super Duplex)

### Material

- Super Duplex Stainless Steel

### Features

- Exceptional strength and rigidity for high-load systems
- Superior resistance to pitting, erosion, and stress corrosion
- High stability in chloride, acidic, and oxidizing environments
- Ideal for aggressive chemical and high-temperature processes

### Typical Applications

- Offshore & marine suspension systems
- High-temperature crystallization processes
- Aggressive corrosive or oxidizing media
- Multiphase solid-liquid suspensions

### Advantages

- Maximum corrosion & erosion resistance
- Long operational lifespan
- Reliable performance in severe process conditions

