

Top Entry Agitators | NP Series

Professional Mixing Technologies

NP Series Agitators Overview

The NP Series top-entry agitators are specifically designed for mixing tanks operating under atmospheric pressure. These agitators ensure high mixing efficiency and are particularly ideal for industries such as chemistry, food, pharmaceuticals, and process industries requiring low to medium viscosity fluid homogenization. They are suitable for processes that demand energy efficiency and low shear mixing.

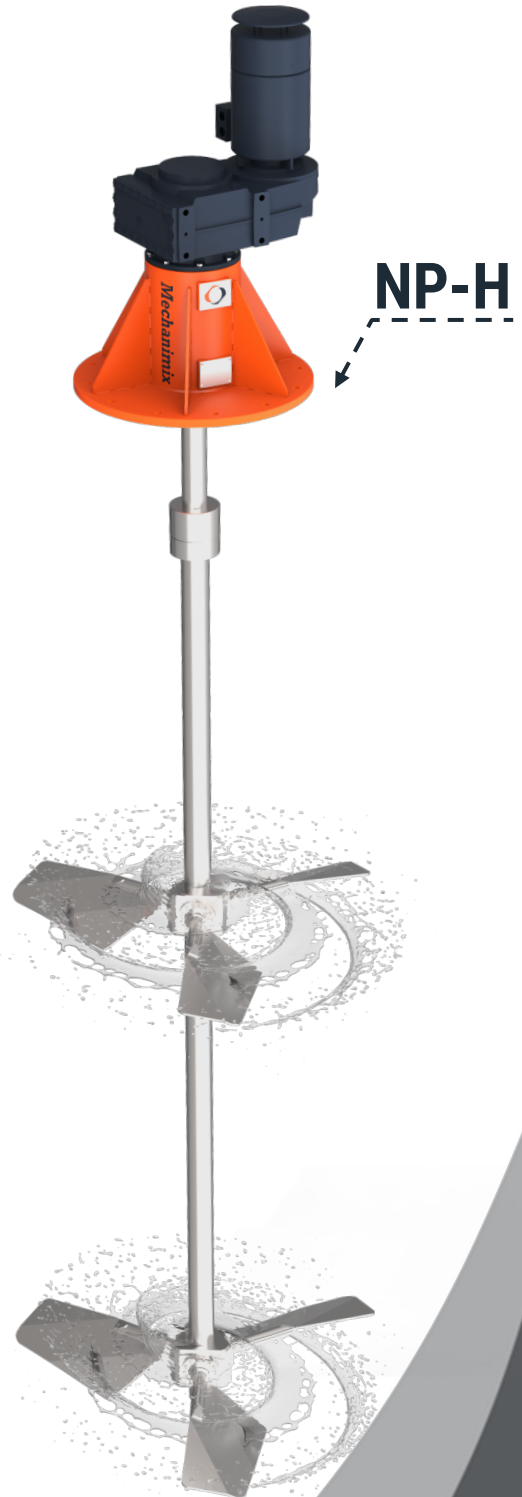

Mechanimix offers high-efficiency mixing solutions for various industries. Our top-entry agitators are designed to provide maximum efficiency with minimum energy consumption. They are developed by evaluating the physical and chemical properties of the product, process outcomes, and tank geometries. We offer sector-specific and need-oriented designs with smart engineering solutions tailored for your process.



Impeller Type	GM, GDM, GDS, HWM, HWM-B
Impeller Diameter	300-8000 [mm]
Shaft Diameter	20-220 [mm]
Shaft Length	Up to 15 [m], in 3 stages
Motor Power	Up to 132 [kW]
Materials	Painted carbon steel, stainless steel, high-performance special alloys
Models	NP-H, NP-M and derivatives
Industries	Biotech, Water & Wastewater, Food & Beverage, Petrochemicals, Detergents, Cosmetics, Chemicals, Oil, Slurry, Raw Materials

Overview

Professional Mixing Technologies

Views		
Series	NP-M	NP-H
Applications	<ul style="list-style-type: none"> – Bearing design resistant to moderate radial and axial loads – Batch Process Optimization – Medium-scale Mixing & Storage 	<ul style="list-style-type: none"> – Large-scale Mixing & Storage – Bulk Slurry Agitation (mineral slurries) – Gas Dispersion in Large Tanks – Continuous Process Operations
	<ul style="list-style-type: none"> – Liquid Homogenization – Medium Viscosity Products (syrops, emulsions) – Solid Suspension (light/medium density) – Miscible Liquid Blending – Heat Transfer Enhancement – Dissolution Processes 	
Features	<ul style="list-style-type: none"> – Medium and Heavy-Duty Drive Unit – Space-saving and ease of installation – Advanced Condition Monitoring Service – Quiet and Vibration-Free Operation – Available with IEC & NEMA motors, both 50Hz & 60Hz options – Ex-Proof Design for Hazardous Environments – Easily configurable motor, gearbox, and shaft for diverse applications – Optimized, leak-proof, and safe for non-pressurized processes 	
Advantages	<ul style="list-style-type: none"> • Minimum Downtime • Low Operating Costs • Environmental Sustainability 	<ul style="list-style-type: none"> • Flexible Use • Process Optimization • Reliable Performance

Two Models, One Reliable Solution

NP series top entry agitators are offered in two different models: NP-M (Medium Duty) and NP-H (Heavy Duty).

The appropriate model selection is determined by the volume of the tank to be mixed and the process requirements, thus ensuring maximum performance and long equipment life.

- ❖ To review all the technical details regarding the service, please take a look at the brochure we have prepared specifically for the [Condition Monitoring Service](#).

CFD Studies

Professional Mixing Technologies

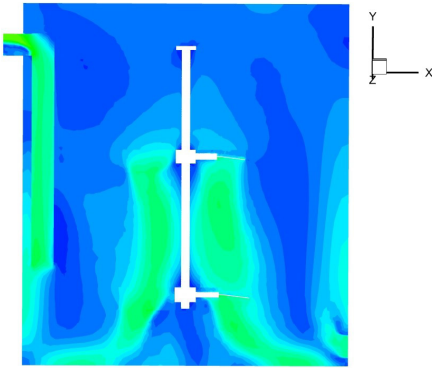

CFD Post A

Streamlines & Vector Fields

- Optimal mixing performance ensuring product integrity
- Color-scale visualization of tank velocity distribution
- Minimal dead zones within the tank
- Symmetrical flow pattern indicating uniform liquid distribution
- Blue=low velocity, Green=high velocity

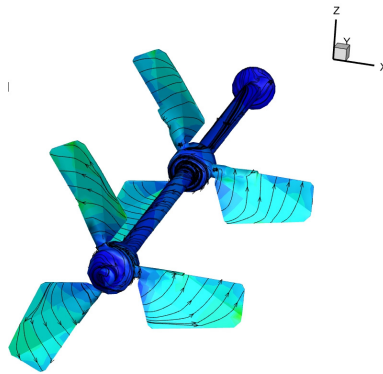

CFD Post B

Particle Tracking Visualization

- Flow lines and directed currents visualized inside the tank
- 3D circulation generated by the impeller enables horizontal and vertical movement
- Cyclical flow prevents sedimentation and improves solute dissolution
- Top-to-bottom and diagonal flow ensures full utilization of tank volume

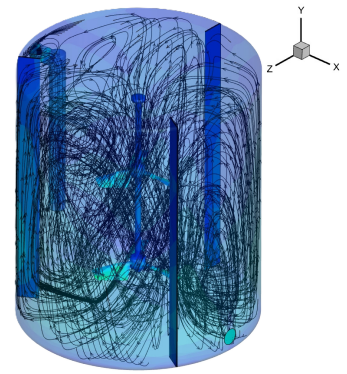

CFD Post C

Velocity Gradient Map

- Particle paths in the liquid are visualized during operation
- Turbulence and rotational motion ensure full-volume particle distribution
- Enables complete mixing of additives, pigments, flocculants, and chemicals
- Demonstrates both volumetric and dynamic continuity of the mixture

Computational Fluid Dynamics (CFD)

CFD analysis can be performed on real tank and agitator combinations to verify the desired process outcome. Mechanimix has many years of experience using CFD simulations.



Features

Professional Mixing Technologies

Hygienic Design

- High surface quality to eliminate dead spots and prevent bacterial growth
- Food-grade oil for gear lubrication
- Special TH flange to prevent external leakage into the tank
- Choice of baffle-less eccentric or hygienic baffled configuration



Homogeneous Stirring



Agitator Coatings

- Tailored coatings for small-to-large agitators in aggressive environments
- Rubber, polyethylene, or ceramic coatings for mineral processing and similar industries
- Agitator coatings matched to tank surfaces to prevent wear or chemical reaction
- Seals and clearances designed to protect coating integrity under stress

Fast Mixing





Flash agitators are designed for rapid chemical blending, often used before the flocculation stage. This uniform distribution often requires intense turbulence, but in non-viscous environments, compact and low-speed direct-drive agitators are sufficient.

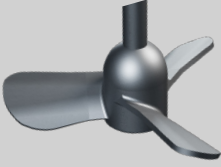
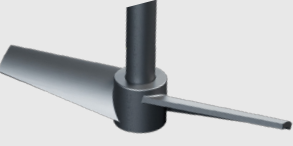

Coated Impellers

NP Series Impeller Integration

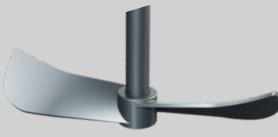
Professional Mixing Technologies

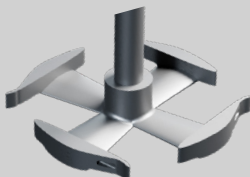
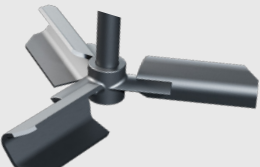
Model	View	Features
HWM		<ul style="list-style-type: none"> – Axial Thrust with Wide Blade Impeller – Application in Low and Medium Viscosity Systems – Homogeneous Energy Distribution – Minimum Local Turbulence
HM		<ul style="list-style-type: none"> – High Flow at Bottom for Solid Suspension – Efficient Mixing in Low/Medium Viscosity – Enhanced Wall Heat Transfer via Axial Flow – Single and Multiple Impeller Arrays – Double, Triple or Quadruple Blade Design – Adjustable Blade Angle
HWM-B		<ul style="list-style-type: none"> – Low, Internal Cutting Force – High Suspension – Homogenizing Function – Working in Gaseous Environments – Supporting Heat Transfer
HVM		<ul style="list-style-type: none"> – For High Viscosity or Critical Rheology Fluids – Upward or Downward Pumping as Needed – Ideal for Blending, Heat Transfer, or Solid Incorporation – Mixes to Ensure No Dead Zones Form
TVM		<ul style="list-style-type: none"> – Application in Low Viscosity Systems or Turbulent Flow Regime – Excellent Axial Thrust Velocities – It Does Not Leave Dead Spots Inside the Tank Inner Wall – Auxiliary impeller enhancing horizontal flow & circulation in tall tanks
GDM		<ul style="list-style-type: none"> – High Suspension Performance Even at High Gas Flow Rates – Radial Thrust Impeller – Main Gas Distributor Role – Works Easily with Gas in Internal and External Power Supply
GM		<ul style="list-style-type: none"> – High Gas Supply Capacity – High Contact Surface Area – Specially Shaped Gas Channels – Homogeneous Energy Distribution – Optimum Suction Power
GDS		<ul style="list-style-type: none"> – Combines Strong Radial and Axial Flows – Excellent Gas Distribution Performance – Fast Mixing – Low Power Consumption – Fully Compatible with Mechanimix GDM

NP Series Modular Design

Professional Mixing Technologies

Adjustable Blade Angle

Features	Description
Rotatable Blades	Each blade can rotate around its axis via a bolted shaft connection.
Flow & Intensity Control	Adjusting the angle regulates flow direction, flow rate, and mixing intensity.
Process Optimization	Enables fine-tuning of axial/radial flow ratios without impeller or drive changes.
Efficiency Gains	Shortens cycle time, improves process control, and enhances energy use.
Commissioning Flexibility	Offers maximum adaptability during setup and operational adjustments.
Maintenance-Friendly	Allows easy adjustments without major disassembly.
High-Performance Design	Provides precise process control and robust operation.
Modular Compatibility	Integrates with various drives, impellers and shaft lengths.

Bearing Housing Unit

In NP series agitators, the bearing housing ensures operational stability with a high-rigidity design that withstands dynamic loads from shaft rotation and impeller motion. It accommodates thermal expansion and minimizes misalignment, reducing stress on the bearings. This results in smoother, quieter, and more reliable long-term performance.

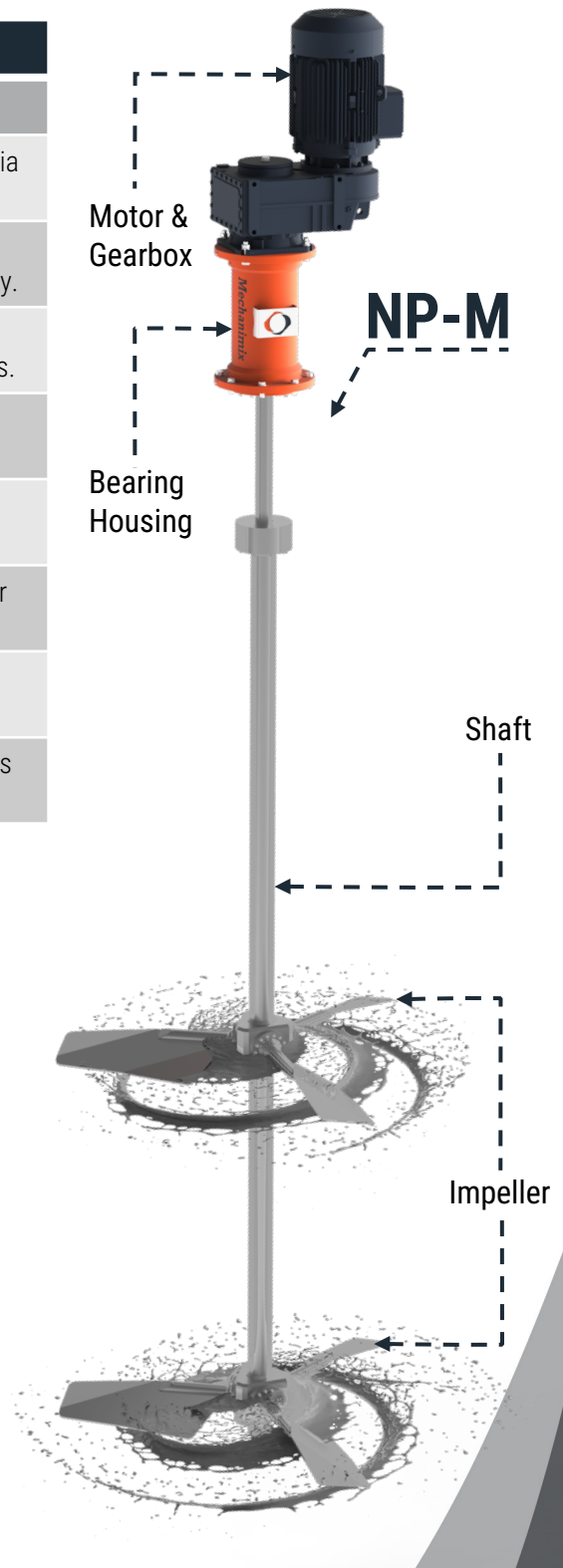
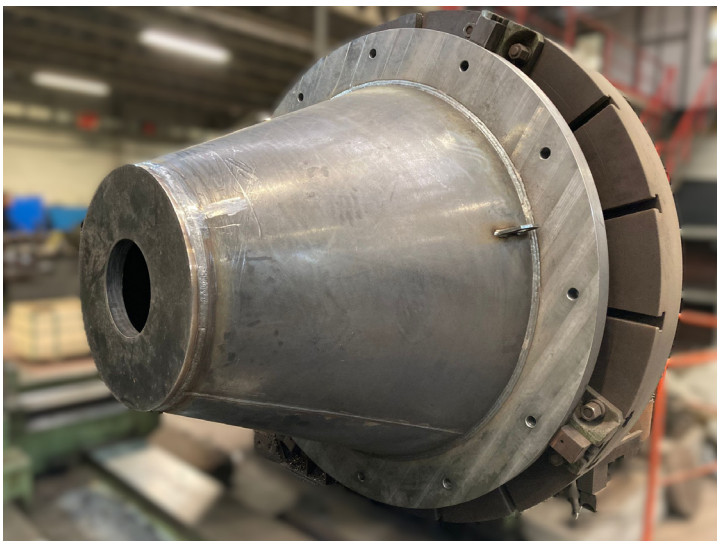

NP Series Agitator Applications

Professional Mixing Technologies

Industry	Process	Key Requirements / Agitator Features
Water & Wastewater	Nitrification/Denitrification	<ul style="list-style-type: none"> Prevents sedimentation without air entrainment Reliable continuous operation NP Series flash & denitrification agitators
	Flocculation	<ul style="list-style-type: none"> Gentle, uniform agitation Low-shear, high-torque operation Energy-efficient, precise process control
	Anaerobic Digestion	<ul style="list-style-type: none"> Efficient sludge suspension Maximizes biogas yield Optimized impeller for low energy consumption
	Desulphurization/ Sulphurization	<ul style="list-style-type: none"> Homogeneous gas-liquid / solid-liquid mixing Robust design for continuous chemical reaction NP Series agitators preferred
Food & Beverage	Sugar Syrup/Flavor Mixing	<ul style="list-style-type: none"> Hygienic design, CIP compliant Precise mixing of Newtonian & non-Newtonian fluids
	Pulp & Particulate Suspension	<ul style="list-style-type: none"> Uniform distribution of fruit pulp & solids Prevents settling during storage & processing
Mining & Metals	Conditioning/Precipitation	<ul style="list-style-type: none"> Handles abrasive slurries Heavy-duty shafts & gear units Reliable operation in harsh chemical environments
	Reagent Preparation	<ul style="list-style-type: none"> Uniform dispersion of chemicals Consistent performance under continuous duty
Fertilizer & Chemicals	Slurry Mixing & Reaction	<ul style="list-style-type: none"> Corrosion-resistant materials Prevents sedimentation Long service life in aggressive media
Paper & Pulp	Vertical Agitated Storage Tanks	<ul style="list-style-type: none"> Maintains homogeneity of viscous suspensions Prevents filler & pigment settling
Biofuels & Biochemicals	Biodiesel/ Biogas Production	<ul style="list-style-type: none"> Energy-efficient mixing for sustainable production Versatile impeller options for various feedstocks

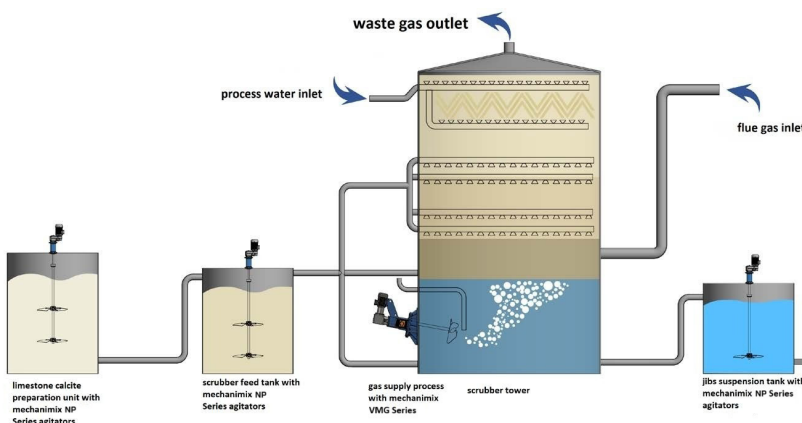



Mechanimix

NP Series Agitator Dimensions

Professional Mixing Technologies



Suitable for use in tanks with capacities ranging from 1 m³ to 2000 m³.
Designed to accommodate various flow characteristics and a wide range of viscosities.

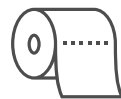
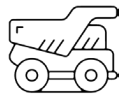
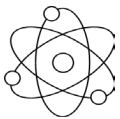

Mechanimix offers a comprehensive range of non-pressurized industrial agitators designed to meet the needs of general mixing applications across a wide range of industries. With multiple configuration options, it ensures efficient and reliable performance in atmospheric or open-tank conditions.

