

Impellers | HMW-B Series

Professional Mixing Technologies

Next Generation Efficiency in Mechanical Mixing Technologies

Mechanimix offers advanced impeller solutions that combine high efficiency, versatility, and process optimization across a wide viscosity range. The HM hydrofoil impeller is specifically engineered to deliver exceptional pumping capacity, rapid mixing, and enhanced solid suspension performance. Its hydrodynamic blade profile ensures high flow rates with low energy consumption, improving heat transfer and overall process reliability. Ideal for use in industries such as minerals, chemicals, polymers, biofuels, and water treatment, the HM provides consistent, energy-efficient mixing performance from laboratory to full-scale operations.

INDUSTRIES

- Chemical industry
- Polymer processing
- Active Pharmaceutical Ingredient (API) production
- Formulated consumables
- Hydrometallurgy

APPLICATIONS

- Crystallization & precipitation processes
- Multipurpose production systems
- Suspension & emulsion polymerization

ADVANTAGES

- Low shear mixing suitable for sensitive materials
- High heat-transfer efficiency
- Reduced mixing time with optimized flow design
- Stable solid suspension even in gas-liquid systems

FEATURES

- Axial Pumping Wide Blade Impeller
- Ideal for low- to medium-viscosity fluids
- Uniform energy distribution for consistent process results
- Minimal local turbulence improves product quality

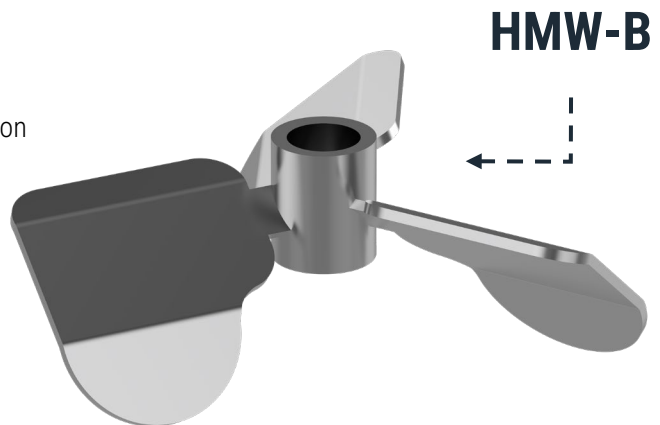

Material Variants and Application Range

Professional Mixing Technologies



HMW-B
(Stainless Steel)

Material

- High-grade stainless steel

Features

- Low-shear wide-blade propeller design
- Smooth, polished surface for hygienic applications
- Efficient axial flow with minimal turbulence
- Easy to clean and suitable for CIP systems

Typical Applications

- Crystallization and precipitation
- Polymerization (suspension / emulsion)
- API and fine-chemical production
- Multipurpose processing plants
- Emulsion preparation and blending

Advantages

- Gentle mixing for shear-sensitive materials
- High heat-transfer efficiency
- Fast and consistent mixing performance

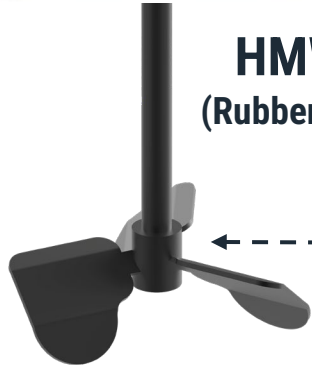

HMW-B
(Rubber Lining)

Material

- Carbon-steel impeller body with rubber lining

Features

- Superior resistance to abrasive slurries
- Rubber layer absorbs particle impact and reduces wear
- Suitable for solid-rich or slurry-based processes
- Provides smooth, stable flow with low turbulence

Typical Applications

- Slurry crystallization and slurry polymerization
- Leaching and hydrometallurgy
- Acidic or particle-rich environments
- Fertilizer and phosphate-based processes

Advantages

- Extended service life in abrasive conditions
- Reduced mechanical wear on blades
- Lower maintenance requirements

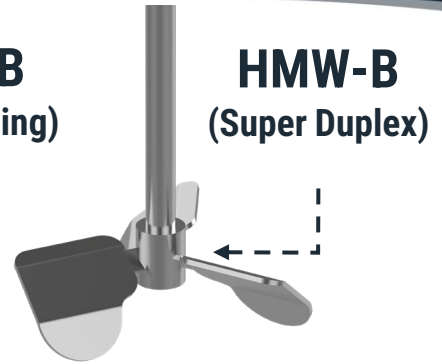

HMW-B
(Super Duplex)

Material

- Super Duplex Stainless Steel

Features

- Outstanding mechanical strength and rigidity
- Excellent resistance to pitting and stress corrosion
- High stability in chloride, acidic, and oxidizing media
- Ideal for aggressive high-temperature environments

Typical Applications

- Offshore & marine chemical systems
- High-temperature / high-pressure crystallization
- Aggressive corrosive or oxidizing chemical media
- Multiphase blending in extreme conditions

Advantages

- Maximum corrosion & erosion resistance
- Long equipment lifespan
- Reliable operation under severe process conditions

