

Impellers | HM Series

Professional Mixing Technologies

Next Generation Efficiency in Mechanical Mixing Technologies

Mechanimix offers advanced impeller solutions that combine high efficiency, versatility, and process optimization across a wide viscosity range. The HM hydrofoil impeller is specifically engineered to deliver exceptional pumping capacity, rapid mixing, and enhanced solid suspension performance. Its hydrodynamic blade profile ensures high flow rates with low energy consumption, improving heat transfer and overall process reliability. Ideal for use in industries such as minerals, chemicals, polymers, biofuels, and water treatment, the HM provides consistent, energy-efficient mixing performance from laboratory to full-scale operations.

INDUSTRIES

- Minerals
- Chemicals
- Polymers
- Formulated Consumer Products
- Flue Gas Desulfurization
- Water Treatment
- Biofuels and Biorefineries
- Hydrometallurgy

APPLICATIONS

- Mixing and Storage Tanks
- Reactors
- Crystallization and Precipitation
- Leaching Processes
- Polymerization (suspension, emulsion)

ADVANTAGES

- High Pumping Power, Fast Mixing
- High Flow Rates
- Increased Heat Transfer Rates
- Excellent Solid Suspension Performance
- Easy Cleaning

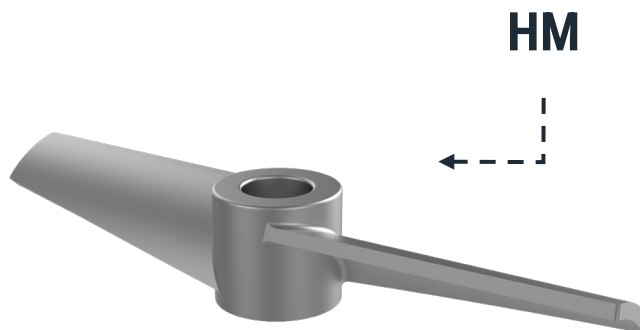

FEATURES

- Multi-Purpose Impeller
- Wide Viscosity Range, Non-Newtonian
- Standard Versions with 23° and 56° Blade Angle
- Variable Blade Angles
- 2, 3 or 4 Propeller Blade Options



Material Variants and Application Range

Professional Mixing Technologies

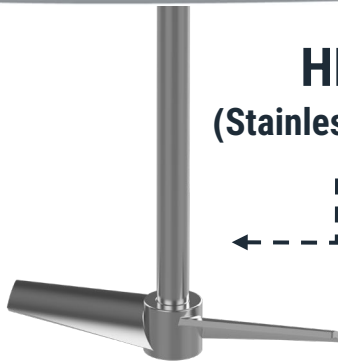

HM
(Stainless Steel)

Material

- High-grade stainless steel

Features

- Excellent corrosion and chemical resistance
- Smooth, polished surface for hygienic operation
- Optimized hydrofoil design for efficient flow and low power consumption
- Easy to clean and suitable for CIP (Clean-In-Place) systems

Typical Applications

- Chemical, polymer, and food industries
- Water and wastewater treatment
- Crystallization and suspension mixing
- Processes involving mild to moderately aggressive chemicals

Advantages

- Reliable and durable in diverse process conditions
- High pumping efficiency and fast mixing
- Long service life with minimal maintenance

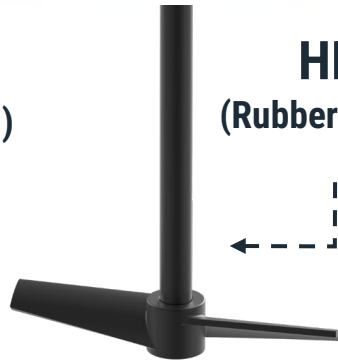

HM
(Rubber Lining)

Material

- Carbon-steel impeller body with rubber lining

Features

- Superior resistance to abrasion and corrosive slurries
- Rubber coating absorbs particle impact and reduces wear
- Suitable for high-solid-content and slurry mixing processes
- Provides smooth flow with minimal turbulence

Typical Applications

- Mining and hydrometallurgy
- Slurry and leaching processes
- Acidic or particle-rich process environments
- Phosphate and fertilizer production

Advantages

- Extended service life in abrasive conditions
- Reduced mechanical wear on impeller blades
- Stable performance with lower maintenance costs

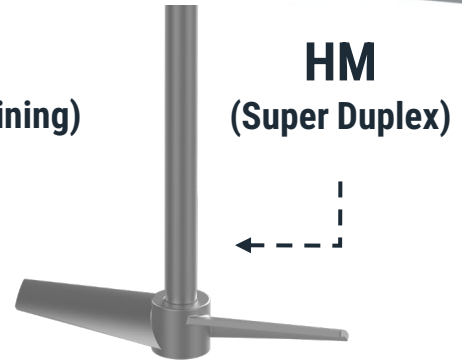

HM
(Super Duplex)

Material

- Super Duplex Stainless Steel

Features

- Exceptional mechanical strength and rigidity
- Excellent resistance to pitting and stress corrosion cracking
- High stability in chloride-, acid-, and high-pressure environments
- Suitable for aggressive or oxidizing process media

Typical Applications

- Offshore and marine chemical systems
- High-temperature / high-pressure chemical processes
- Aggressive corrosive or oxidizing media

Advantages

- Maximum corrosion and erosion resistance
- Extended equipment lifespan
- Reliable operation under extreme conditions

